



Although we offer a full line of products and services, we have attempted show case some of our most popular products and frequently shipped items. This catalogue 'at-a-glance' should not replace our full catalogue, which can be found by visiting our website, www.magnoliametal.com, and clicking the products tab. As always should you have any questions please do not hesitate to contact us. We wish you continued success in your business and hope that we can help you become stronger and more profitable in the process.

Most Sincerely,



The Magnolia Metal Team

Inside you'll find information for:

Screen Frame	Page 2 thru 10
Screen Frame Components.....	Page 2 thru 10
Spline	Page 11
Specialty Tools	Page 11
Phifer Screen Cloth	Page 12
Patio Screen Door & Components.....	Page 13-17
Patio Screen Room Enclosure Material....	Page 18-19
Color Availability.....	Page 20
Measurement & Conversion Chart.....	Page 21
Product Code Information.....	Page 22
Terms & Sale Conditions.....	Page 23
Magnolia Metal Credit Application.....	Page 24

**For information about our full line of retractable screens, Patio Enclosure Systems, and Heavy Duty Screen Doors, please go visit our website: www.magnoliascreencomp.com or email sales@magnoliametal.com.

*101 County Lane * Vicksburg, MS 39183*

*Local(601)638-6912*TollFree(800)638-6912*

www.magnoliametal.com







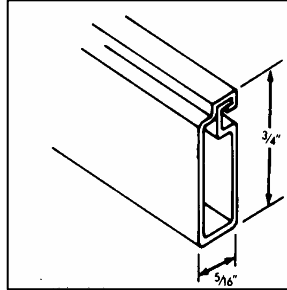







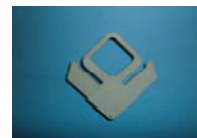

Product #	Description	Pieces / Carton	Feet / Carton
V-11	5/16" x 3/4"	160	2000 / 12'6"
			2560 / 16'

Available Colors
Black * Bronze * Desert Sand Champagne* Mill * White



Please note screen corners may have many different product numbers. Product numbers listed below are for reference purposes only. Please call your sales representative for assistance.

CORNERS

				
20000110-SW	20000108	2000248	20000142	
Safety Warning Corner	External with Tab	With Tab and Peg	With Tab and Stop	
				
20000146	V6-611	V6-211	20000109	V6-811
With Tab and 1/2 Ball	With Protruded Stop	Sq. Cut External Corner	External Corner	External Corner
				
20000111	20000107	V6-11	V6-311	
External Corner	Plastic Internal Corner	Plastic Internal Corner	With Dimple	
				
	A6-11			
	Aluminum Corner			







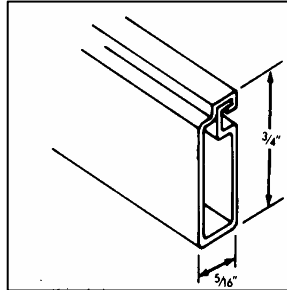





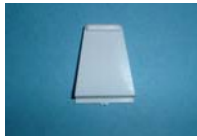







Product #	Description	Pieces / Carton	Feet / Carton
V-11	5/16" x 3/4"	160	2000 / 12'6" 2560 / 16'

Available Colors
Black * Bronze * Desert Sand Champagne * Mill * White



Please note screen components may have many different product numbers. Product numbers listed below are for reference purposes only. Please call your sales representative for assistance.

COMPONENTS

				
V8-099	V8-100	V8-039	V8-010	V6-306
Pull Tab	Hollow Pull Tab	Loop Latch	Ball Head Screw	Swivel Button Latch
				
V8-0082	V6-307	Various Styles	Various Sizes	Various Styles
Check Clip	Pop Rivet	Plunger Pin	Spring for Plunger	Plunger Cap
				
475 & 475-L	V8-007	V8-035	V8-020	V8-3769
Auto-Lock Spring	Tension Spring	Leaf Spring	Ram Horn Spring	Leaf Spring Corner Type
				
PE 140	CB-817	V8-15	V8-300	HWD
.140 Spline	Center Bar Insert	Friction Hanger	Nail for Friction Hanger	For D/H Screens



Product #	Description	Pieces / Carton	Feet / Carton
V-15	7/16" x 11/16"	144	1800 / 12'6"
			2328 / 16'2"

Available Colors
Black * Bronze Champagne * Desert Sand Mill * White

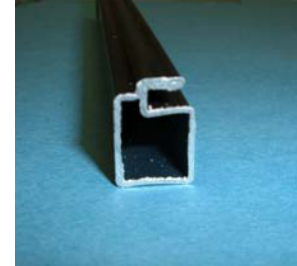
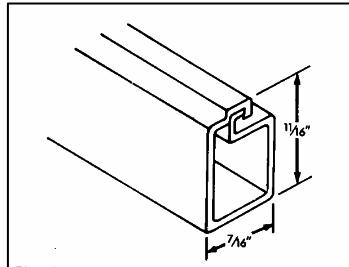

Please note screen corners may have many different product numbers. Product numbers listed below are for reference purposes only. Please call your sales representative for assistance.

CORNERS

20000219	20000218-SW	20000218	V6-215
External Corner	Safety Warning Corner	External w/ Pull Tab	External Corner
20000181	A6-15	V6-15	
Internal Folding Corner	Corner Insert	Internal Corner	



Product #	Description	Pieces / Carton	Feet / Carton
V-15	7/16" x 11/16"	144	1800 / 12'6"
			2328 / 16'2"

Available Colors
Black * Bronze Champagne * Desert Sand Mill * White

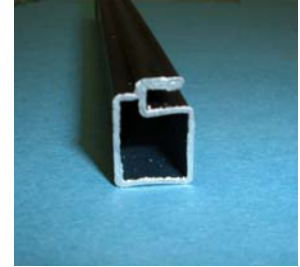
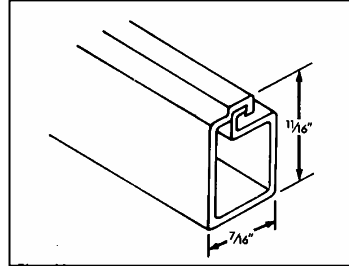

Please note screen components may have many different product numbers. Product numbers listed below are for reference purposes only. Please call your sales representative for assistance.

COMPONENTS

V8-099	V8-100	V8-039	V8-010	V6-306
Pull Tab	Hollow Pull Tab	Loop Latch	Ball Head Screw	Swivel Button Latch
V8-0082	V6-307	Various Styles	74-102	Various Styles
Check Clip	Pop Rivet	Aluminum Plunger Pin	Nylon Plunger Pin	Plunger Cap
Various Sizes	PE 140	V8-15	V8-300	HWD
Spring for Plunger	.140 Spline	Friction Hanger	Nail for Friction Hanger	Bags for D/H Screens
V8-020	V8-3769		475 & 475-L	V8-035
Ram Horn Spring	Leaf Spring Corner Type		Auto Lock Spring	Leaf Spring



Product #	Description	Pieces / Carton	Feet / Carton
V-21	1/4" x 3/4"	180	2250 / 12'6"

Available Colors
Bronze * Mill * White

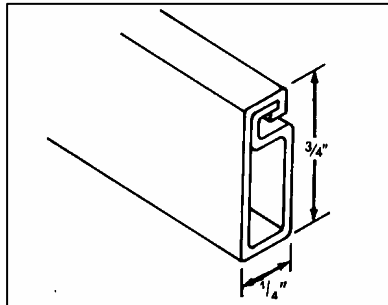

Please note screen components may have many different product numbers. Product numbers listed below are for reference purposes only. Please call your sales representative for assistance.

COMPONENTS

V8-099	V8-100	A6-21	PE 140	V6-306
Pull Tab	Hollow Pull Tab	Corner Inserts	.140 Spline	Swivel Latch
V8-0082	V6-307	Various Styles	Various Sizes	Various Styles
Check Clip	Pop Rivet	Aluminum Plunger Pin	Spring for Plunger	Plunger Cap
2000150	V8-007	V8-035		
Leaf Spring Corner Type	Tension Spring	Leaf Spring		



Product #	Description	Pieces / Carton	Feet / Carton
V-51	3/8" X 2 1/32"	1	1250/12'6"

Available Colors
Bronze * White

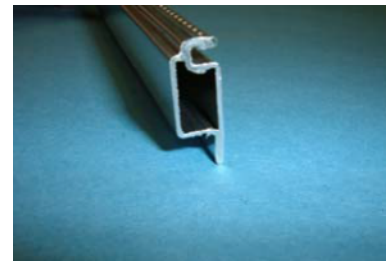
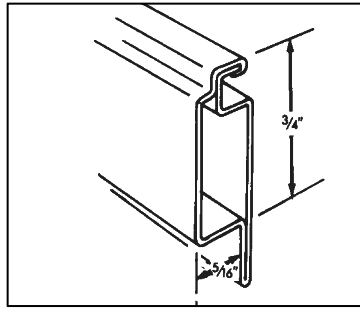

Please note screen components may have many different product numbers. Product numbers listed below are for reference purposes only. Please call your sales representative for assistance.

COMPONENTS

V8-099	V8-100	V8-039	V8-010	V6-306
Pull Tab	Hollow Pull Tab	Loop Latch	Ball Head Screw	Swivel Latch
V8-0082	V6-307	Various Styles	Various Sizes	Various Styles
Check Clip	Pop Rivet	Plunger Pin	Spring for Plunger	Plunger Cap
475 & 475-L	V8-007	V8-035	V8-020	V8-3769
Auto-Lock Spring	Tension Spring	Leaf Spring	Ram Horn Spring	Leaf Spring Corner Type
PE 140	CB-817	V8-15	V8-300	HWD
.140 Spline	Center Bar Insert	Friction Hanger	Nail for Friction Hanger	For D/H Screens



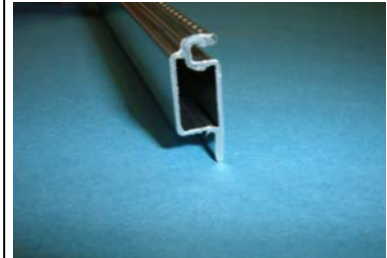
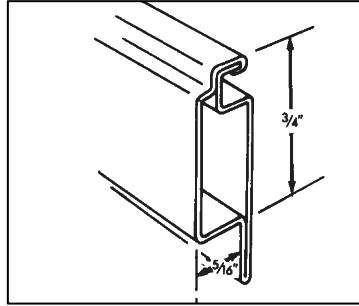

Product #	Description	Pieces / Carton	Feet / Carton
V-51	3/8" X 2 1/32"	1	1250/12'6"

Available Colors
Bronze * White



Please note screen corners may have many different product numbers. Product numbers listed below are for reference purposes only. Please call your sales representative for assistance.

CORNERS

V6-251		
External w/ Flange	A6-11	V6-11
	Aluminum Corner	Plastic Internal Corner



Product #	Description	Pieces / Carton	Feet / Carton
V-88	3/8" x 3/4"	140	1750 / 12'6" 2240 / 16"

Available Colors		
Black * Bronze Champagne * Desert Sand Mill * White		

Please note screen corners may have many different product numbers. Product numbers listed below are for reference purposes only. Please call your sales representative for assistance.

CORNERS

20000110-SW	20000118	A6-88
Safety Warning Corner	Pull Tab Corner	Aluminum Corner
V6-88	V6-288	V6-688
Plastic Internal Corner	External Corner	Ext. Cnr w/ Protruded Stop





Product #	Description	Pieces / Carton	Feet / Carton
V-99	7/16" x 1".025	72	900 12' 6"
			Special Order

Available Colors
Bronze * Mill * White

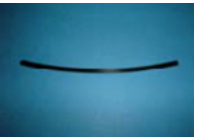

Please note screen corners may have many different product numbers. Product numbers listed below are for reference purposes only. Please call your sales representative for assistance.

CORNERS & Accessories

		
.220 Spline	V-99	A6-99
Safety Warning Corner	Frame	Aluminum Corner



We extrude all of our Spline in-house. Below is a sampling:



<u>Diameter</u>	<u>FT/Roll</u>	<u>Type</u>
0.115	350	PVC
0.175	350	PVC
0.120	3000	Foam/PE
0.125	3000	Foam/PE
thru	3000	Foam/PE
0.155	3000	Foam/PE
0.160	3000	Foam/PE
0.165	3000	Foam/PE
0.170	2500	Foam/PE
0.175	2500	Foam/PE
0.180	2500	Foam/PE
0.185	2000	Foam/PE
0.190	2000	Foam/PE
0.200	1500	Foam/PE
thru	1500	Foam/PE
0.270	1500	Foam/PE
PVC		
0.120	1500	Serrated
thru	1500	Serrated
0.165	1500	Serrated
PVC		
0.170	1500	Serrated
0.180	1500	Serrated
0.185	1500	Serrated
0.190	1500	Serrated
PVC		
0.200	1500	Serrated
thru	1500	Serrated
0.270	1500	Serrated
0.210	350	PVC

We stock spline in Black only; however, spline can be special ordered in Grey and White.

Flat Spline is also available!

We stock PVC .260 thru .350 on 1000' spools.

Spline can be special ordered to meet almost any need. Email sales@magnoliametal.com for details.

*101 County Lane * Vicksburg, MS 39183*

*Local(601)638-6912*TollFree(800)638-6912*

www.magnoliametal.com



As a factory direct distributor for Phifer, we offer the following Screen Cloth Options:

- No-See-Um Cloth 20x20 Mesh 100 Ft Rolls
- Phifer Insect Screen Cloth
- Phifer Solar Screen Cloth
- Phifer Solar Screen Cloth Cut Lengths (By The Foot)
- Phifer Improved Visibility Screen Cloth
- Phifer Pet Screen
- Phifer Pool & Patio Cloth

BENEFITS	PRODUCTS												
	18 x 14 Fiberglass Charcoal	Fiberglass Charcoal	Fiberglass Silver Gray	Super Solar Screen	SunTex®	SunScreen®	No-See-Ums (20 x 20)	Solar Insect Screen (20 x 30)	SeeVue™ Stainless Screen	PetScreen®	Brite Aluminum	Charcoal Aluminum	Bronze Screen
Pool enclosures	1	2					2						
Patio & porches	1	1	1	3	3	3	1	3	1	2	1	1	1
Insect protection	2	2	2	1	1	2	1	1	2	2	2	2	2
Visibility	1	1	2	2	2	3	2	2	1	2	2	1	2
Ventilation	1	1	1	3	3	3	2	2	2	2	1	1	1
Sun block				1	1	2		2		3			
Durability	2	2	2	2	2	1	2	2	1	1	1	1	1
Daytime privacy				1	1	1	2	1	3	1	3	3	3
Reduces fading				1	1	1		2		3			
Energy saving				1	1	1		2		3			
Resist pet damage					1	1				1			
Easy to install	1	1	1	2	2	2	1	1	2	2	2	2	3

1 - Best

2 - Better

3 - Good

101 County Lane * Vicksburg, MS 39183

Local(601)638-6912*TollFree(800)638-6912

www.magnoliametal.com



HEAVY DUTY ALUMINUM PATIO SCREEN DOOR
Fully Fabricated * Call for Information

Call Size	Approximate Size	Doors / Carton
4068	24 x 80	10
5068	30 x 80	10
6068	36 x 80	10
8068	48 x 80	10
CUSTOM SIZING IS AVAILABLE FOR ALL PATIO SCREEN DOORS.		



DETAILED INFORMATION
Frame 1/2" x 1 5/8" 1" Nylon Rollers 1 3/8" Bug Flap 18 x 16 Mesh Fiberglass Screen Cloth (Packed 5 Doors Per Carton - Minimum 10 Doors Per Size) Individual or Bulked Packaged Doors Steel or Nylon Rollers Available Top Hung Available

Knock Down Doors Available

COLORS AVAILABLE
Bronze * Champagne Desert Sand Mill * White





PATIO SCREEN DOORS

STANDARD ALUMINUM PATIO SCREEN DOOR

<u>Size</u>	<u>Approximate Size</u>	<u>Doors / Carton</u>
4068	24 x 80	10
7068	28 x 80	10
5068	30 x 80	10
6068	36 x 80	10
10068	40 x 80	10
8068	48 x 80	10
CUSTOM SIZING IS AVAILABLE FOR ALL PATIO SCREEN DOORS.		



DETAILED INFORMATION
Frame 1/2" x 1 5/8" 1" Nylon Rollers 1 3/8" Bug Flap
18 x 16 Mesh Fiberglass Screen Cloth
(Packed 5 Doors Per Carton - Minimum 10 Doors Per Size)
Individual or Bulked Packaged Doors
Steel or Nylon Rollers Available Top Hung Available

**COLORS AVAILABLE: Almond * AW Tan
Bronze * Champagne * Mill * White
Custom Colors Available**



*101 County Lane * Vicksburg, MS 39183*

*Local (601) 638-6912 * Toll Free (800) 638-6912*

www.magnoliametal.com



PATIO SCREEN DOOR COMPONENTS

Page 1 of 3

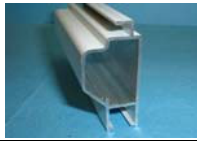
Product #	Description	UM	Pieces / Carton	Visual
PDL	1/2 x 1 5/8 Extruded Patio Screen Frame Available in Bronze, Champagne, Mill, and White	EA	As Required 10' or 11'	
HDPDL	1/2 x 1 5/8 Extruded Patio Screen Frame Available in Bronze, Champagne, Desert Sand, Mill, and White	EA	As Required 10' , 11', or 12'6"	
VE-22	Patio Screen Door Header Available in Bronze and White	Ea	As Required	
20000230	Rigid Pile Adapter Black	Roll	1 Roll	
PDC-103	1 1/2" Vinyl Bug strip	Roll	250'	
PDC-107	Nylon Internal Corner	EA	As Required	
20000197	Heavy Duty Patio Door Corner	EA	As Required	



PATIO SCREEN DOOR COMPONENTS

Product #	Description	UM	Pieces / Carton	Visual
V6-307	Pop Rivet for Handle Available in Mill and Black	EA	As Required	
PDC-101	Nylon Patio Screen Door Roller	EA	As Required	
PDC-105	Steel Patio Screen Door Roller	EA	As Required	
SPL-1000	Spline Roller	EA	As Required	
PVC 175	.175 Serrated Spline PVC	Carton	1000'	
40000100	.600 High Pile W/S	Roll	1 Roll	
HDPDC104	Handle Assembly Set for Heavy Duty Profile	EA	As Required	
PDC-104	Patio Screen Door Handle Assembly	EA	As Required	
HDPDHWD	Heavy Duty Patio Door Hardware Bag - Includes 4 Cnrs, 4 Adj Screws, 4 Steel Rollers,	EA	As Required	



PATIO SCREEN DOOR COMPONENTS

Product #	Description	UM	Pieces / Carton	Visual
PDC-102	Adjusting Screw for Patio Door Roller Black	EA	As Required	
30000100	#8 Black Screw For 20000226	M/PCS	Carton / As Required	
PD-KP	1/4" Steel Keeper	EA	Carton / As Required	
20000198	Patio Door Punch (Arbor Punch)	EA	As Required	
20000198-HP	Knife Replacement Handle Punch	EA	As Required	
20000198-LP	Knife Replacement Latch Punch	EA	As Required	



Product #	Description	Pieces / Carton	Feet / Carton
E002	1" X 2" Enclosure Frame 16' 6"	As Required	

Available Colors
Black * Bronze Beige * White

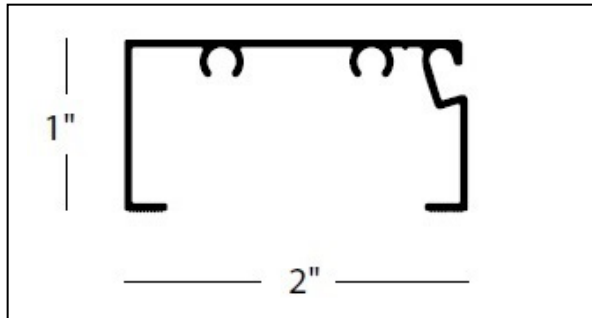

73134	73139	73140	73141	73142
.295 Flat Spline	.305 Flat Spline	.315 Flat Spline	.235 Flat Spline	.310 Flat Spline
73135	73136	73137		
Bronze 5/8" Self Drill Screw	Beige 5/8" Self Drill Screw	White 5/8" Self Drill Screw		

OUR SCREEN ENCLOSURE PRODUCT LINE INCLUDES MANY ADDITIONAL ITEMS.

SCREWS, PICKETS, SELF-MATING FRAME, ETC.







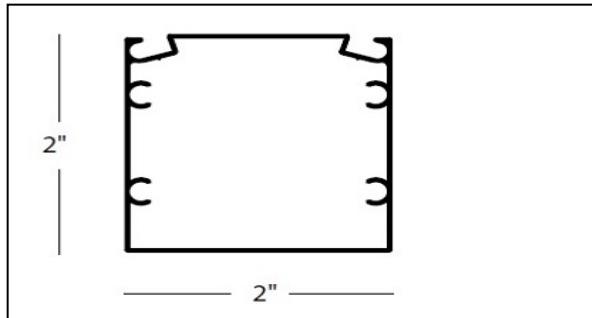

PLEASE CALL DREW OR TONY @ 1-800-638-6912 FOR ADDITIONAL INFORMATION



Product #	Description	Pieces / Carton	Feet / Carton
E003	2" x 2" Enclosure Frame 16' 6"		

Available Colors
Black * Bronze Beige * White



				
73134	73139	73140	73141	73142
.295 Flat Spline	.305 Flat Spline	.315 Flat Spline	.235 Flat Spline	.310 Flat Spline
				
73135	73136	73137		
Bronze 5/8" Self Drill Screw	Beige 5/8" Self Drill Screw	White 5/8" Self Drill Screw		

OUR SCREEN ENCLOSURE PRODUCT LINE INCLUDES MANY ADDITIONAL ITEMS.

SCREWS, PICKETS, SELF-MATING FRAME, ETC.

PLEASE CALL DREW OR TONY @ 1-800-638-6912 FOR ADDITIONAL INFORMATION



STANDARD COLOR AVAILABILITY

	P	R	O	D	U	C	T	S
	COMPONENTS	COMPONENTS	COMPONENTS	COMPONENTS	PATIO DOOR	COMPONENTS	COMPONENTS	COMPONENTS
Almond	X							
Aluminum						X		
AW Tan / Beige	X							
Barefoot Beige	X							
BB White	X							
Black	X						X	X
Blue White	X							
Bronze	X				X		X	
Champagne	X						X	
Charcoal	X					X		
Cream	X							
Creamy White	X							
Desert Sand	X				X		X	
Earthtone	X							
Gold	X							
Gray	X					X		X
Green	X							
Ivory	X						X	
Light Brown	X							
Light Tan	X							
Med. Bronze	X							
Mill	X				X		X	
Northern Brown	X							
Red	X							
SS Bronze	X							
Tan	X							
Taupe	X							
White	X				X			
CUSTOM*	X							

*Please contact our Customer Sales and Service Department for more information about custom made colors and information about new colors not yet listed.

101 County Lane * Vicksburg, MS 39183 Local
 (601) 638-6912 * Toll Free (800) 638-6912
www.magnoliametal.com



CONVERSION CHART

Fractional Inches	Decimal Inches	Millimeters Metric
-------------------	----------------	--------------------

1/64"	0.016"	0.397 mm
1/32"	0.031"	0.794 mm
3/64"	0.047"	1.191 mm
1/16"	0.063"	1.588 mm
5/64"	0.078"	1.984 mm
3/32"	0.094"	2.381 mm
7/64"	0.109"	2.778 mm
1/8"	0.125"	3.175 mm
9/64"	0.141"	3.572 mm
5/32"	0.156"	3.969 mm
11/64"	0.172"	4.366 mm
3/16"	0.188"	4.763 mm
13/64"	0.203"	5.159 mm
7/32"	0.219"	5.556 mm
15/64"	0.234"	5.953 mm
1/4"	0.250"	6.350 mm
17/64"	0.266"	6.747 mm
9/32"	0.281"	7.144 mm
19/64"	0.297"	7.541 mm
5/16"	0.313"	7.938 mm
21/64"	0.328"	8.334 mm
11/32"	0.344"	8.731 mm
23/64"	0.359"	9.128 mm
3/8"	0.375"	9.525 mm
25/64"	0.391"	9.922 mm
13/32"	0.406"	10.319 mm
27/64"	0.422"	10.716mm
7/16"	0.438"	11.113 mm
29/64"	0.453"	11.509mm
15/32"	0.469"	11.906 mm
31/64"	0.484"	12.303 mm
1/2"	0.500"	12.700 mm

Fractional Inches	Decimal Inches	Millimeters Metric
-------------------	----------------	--------------------

33/64"	0.516"	13.097 mm
17/32"	0.531"	13.494 mm
35/64"	0.547"	13.891 mm
9/16"	0.563"	14.288 mm
37/64"	0.578"	14.684 mm
19/32"	0.594"	15.081 mm
39/64"	0.609"	15.478 mm
5/8"	0.625"	15.875 mm
41/64"	0.641"	16.272 mm
21/32"	0.656"	16.669 mm
43/64"	0.672"	17.066 mm
11/16"	0.688"	17.463 mm
45/64"	0.703"	17.859 mm
23/32"	0.719"	18.256 mm
47/64"	0.734"	18.653 mm
3/4"	0.750"	19.050 mm
49/64"	0.766"	19.447mm
25/32"	0.781"	19.844 mm
51/64"	0.797"	20.241 mm
13/16"	0.813"	20.638 mm
53/64"	0.828"	21.034 mm
27/32"	0.844"	21.431 mm
55/64"	0.859"	21.828 mm
7/8"	0.875"	22.225 mm
57/64"	0.891"	22.622 mm
29/32"	0.906"	23.019 mm
59/64"	0.922"	23.416 mm
15/16"	0.938"	23.813 mm
61/64"	0.953"	24.209 mm
31/32"	0.969"	24.606 mm
63/34"	0.984"	25.003 mm
1"	1.000"	25.400 mm



PRODUCT CODE INFORMATION

The following information will help with the understanding of product codes.

CODE	PRODUCT TYPE
------	--------------

A	Aluminum, Bright
AS	Aluminum Screen Cloth
CJ	Concealed Joiner
EC	End Clip
ESF	Extruded Screen Frame
EVA	Hard Serrated Spline
F / FS	Fiberglass Screen Cloth
HD	Heavy Duty / Handle Door Assembly
HDPDL	Heavy Duty Patio Door Lineal
HWD	Hardware Bags
KDPD	Knock Down Patio Door Kit
KL	Knife Latch
MTN	Muntin Bar
PDC	Patio Door Component
PDL	Patio Door Lineal
SB	Star Burst
SP	End Clip with Pad (Spacer Pad)
SPL	Soft Serrated Spline
SS	Sunscreen
SSTC	Stainless Steel Track Cover
TL	Tilt Latch
SW	Safety Warning
NEW	New Products Added Often

CODE	PRODUCT COLOR
------	---------------

A	Almond
BFBG	Barefoot Beige
BBW	Antique White
BLK or B	Black
BLWT	Blue White
B	Bronze
CRM	Cream
CRMWT	Creamy White
CW	Creamy White
DS	Desert Sand
C	Champagne
GRY or G	Gray
GRN	Green
G	Gold or Gray
IV	Ivory
M	Mill
N	Natural
SSB	SS Bronze
T	Tan
TP	Taupe
WHT	White
AWT	AW Tan / Beige
R	Red
NEW	New Colors Added Often



TERMS AND CONDITIONS OF SALE

For accounts approved by our credit department the terms are 1% discounts for payments received within 10 days of invoice date with net due 30 days from invoice date. (1% 10 NET 30) Good credit is an asset to any business. Please help us give your company a good credit rating by keeping your account balance current. All orders will be shipped C.O.D. prior to credit approval.

PAST DUE ACCOUNTS

All accounts with balances past forty-five (45) days will have orders placed on hold until the past due balance is paid to current status. All accounts with balances past sixty (60) days will be placed on C.O.D.

RETURNED CHECKS

Returned checks will be charged a \$25.00 service charge and the account will be placed on C.O.D. Cash on Delivery ONLY.

RETURNS AND ADJUSTMENTS

Approval for material that is being returned must be obtained from our customer service department. A Returned Goods Authorization will be issued for approved returns and must be printed on all shipping documents and bills of lading. No returned materials will be accepted without a valid R. G. A. Number. Unless return is for reasons of defective material or other extenuating circumstances, there will be a 20% restocking charge with a minimum charge of \$5.00. Any claims must be made within 15 days of invoice date.

MINIMUM ORDERS

There is a \$50.00 minimum order per invoice. Individual conditions may vary.

WARRANTY

All products are sold "as is" without warranty, expressed or implied. Included is the condition that the purchaser(s) shall make their own tests to determine the merchant ability of such products for any particular purpose. The liability for Magnolia Metal and Plastic Products, Inc. for special, indirect or consequential damages for injury to property and/or person for anyone or any other loss resulting from a product or failure shall be limited to the purchase price of the product.

FREIGHT

All freight is F. O. B. Vicksburg, Mississippi. Prepay and add with deep discount tariffs are available as an option where applicable.

FREIGHT DAMAGE

All damages must be noted on the freight bill at the time of delivery and reported to customer service within 24 hours of receipt of shipment. An exception number must be obtained from the driver and CLEARLY noted on the freight bill and the bill of lading. Any claims for damages and shortages must be marked clearly on the bill of lading and signed by the driver. If concealed damage is suspected it must be noted on the freight bill and signed by the driver and customer service must be notified within 24 hours of receipt of shipment. A credit memo will be issued to your account only after the freight company approves the claim. No claim for freight damage or shortage will be honored unless notations have been properly made on carriers freight bill at the time the damaged or short shipment is received. The carrier assumes all liability for damages and shortages. The customer is responsible for immediately filing a claim with the carrier. All collect shipments customer is responsible for freight claim. Please see following page titled "Packing Slip Stuffer - Lost / Damaged Information" for best practice directives. Customer Service will gladly help in answering any questions if assistance is needed.

“ Credit Application ”

1-800-638-6912

Magnolia Metal & Plastic Products Inc.

1-601-636-2552,fax

.....
 Billing Name: _____
 Address: _____
 Ship to: _____
 City: _____ . State: _____ Zip: _____
 Years in Business: ____ . Corporation, Y/N. Subsidiary Y/N, if yes who _____
 Phone: __/__/____, Fax: __/__/____ . Email address: _____

**** VERY IMPORTANT: Are you Tax Exempt Yes or No**

If yes please furnish a copy of your Resale Certificate or Direct Pay Permit. If one is not sent you are / could be subject to Sales Tax on all orders.

Parties hereby agree that all purchases made are subject to the following conditions. That billing is payable in full according to the terms as shown on each invoice and all payments are to be made to: **Magnolia Metal & Plastic Products Inc.** at **247 Armory Road Vicksburg MS, 39183**. That billing which is not paid when due shall accrue interest on the net unpaid balance from maturity, paid in full at the rate of 1.5% per month or the maximum legal allowed by law, whichever is less. That the undersigned also agrees to pay, in the event the indebtedness becomes delinquent and is referred to an attorney for collection, reasonable attorney's fees, collection costs and court costs. That no merchandise may be returned without prior authorization, and such returns shall be freight pre-paid and subject to a restocking fee of no less than 25%

DECISION MAKER

ACCOUNT's PAYABLE CONTACT

Name: _____	Name: _____
Signed: _____	Phone: _____ ext: _____
Title: _____	E-mail: _____
SS# _____ / _____ / _____	Fax: _____

CREDIT REFERENCES

Bank: _____ Loan Officer: _____
 Address: _____
 City: _____ State: ____ Zip: ____ . ACCT# _____

***** LIST 4 REFERENCES BELOW *****

1. Vendor: _____ . Phone: __/__/____ Fax: __/__/____
 Address: _____ state/zip: __/____

City: _____

2. Vendor: _____ . Phone: __/__/____ Fax: __/__/____
 Address: _____ state/zip: __/____

City: _____

3. Vendor: _____ . Phone: __/__/____ Fax: __/__/____
 Address: _____ state/zip: __/____

City: _____

4. Vendor: _____ . Phone: __/__/____ Fax: __/__/____
 Address: _____ state/zip: __/____

City: _____

To with our policy please read and complete the Personal Guarantee: In consideration of credit being extended To the aforementioned firm, I personally guarantee all indebtedness hereunder. I further agree is an absolute, Completed & continuing one and no notice of the indebtedness or any extension of credit hereafter contracted by Or need be given. The terms may be rearranged, extended and or renewed without notice to me and that I will, Within 5 days from date of notice to me that the account is past due, pay in full the amount owed.

Guarantor: _____ **Dated:** ____/____/____

WOULD YOU LIKE A MONTHLY STATEMENT MAILED? Yes or no